

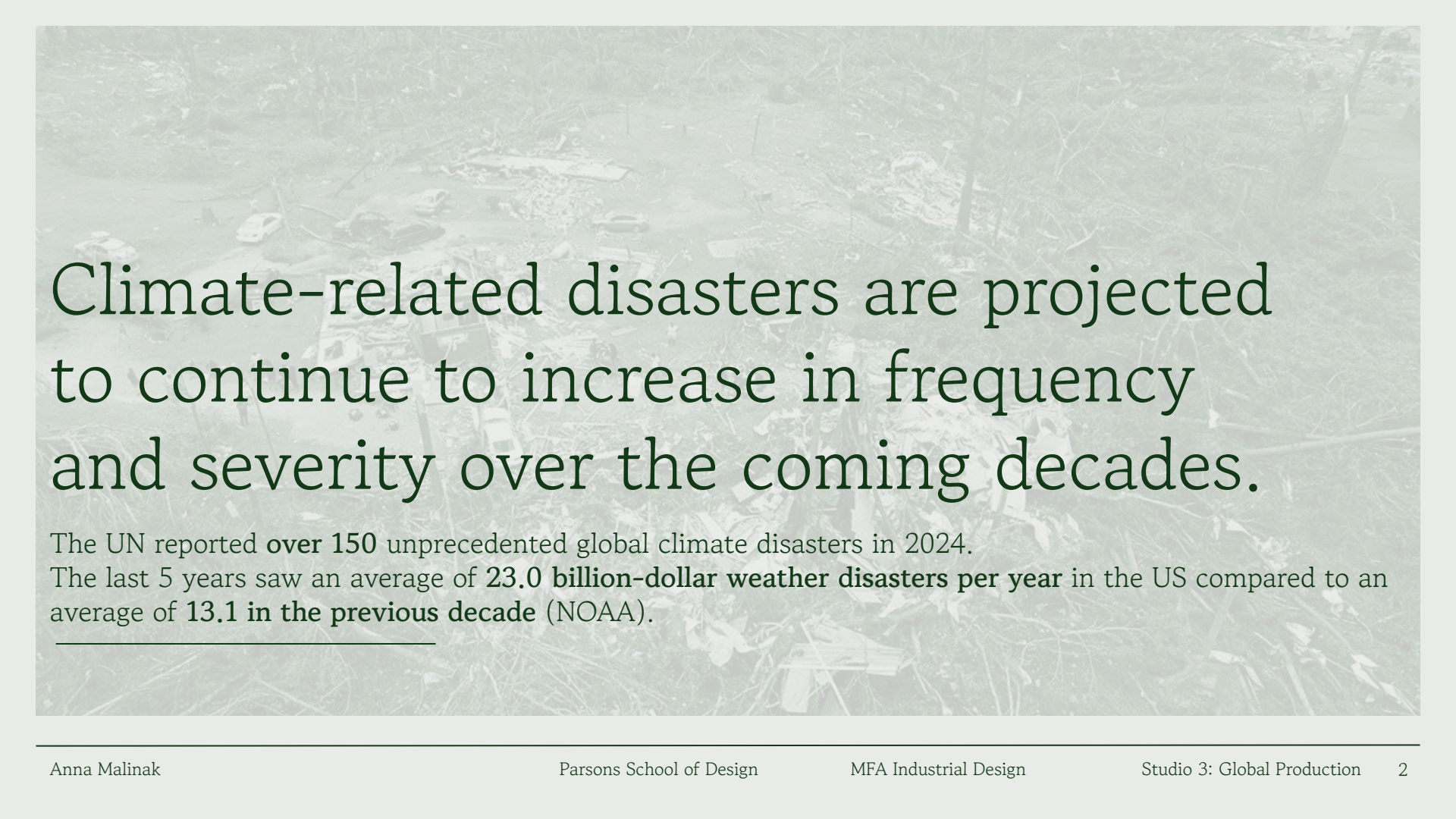

Rising from the Rubble: Rebuilding St. Louis



Climate-related disasters are projected to continue to increase in frequency and severity over the coming decades.

The UN reported **over 150** unprecedented global climate disasters in 2024. The last 5 years saw an average of **23.0 billion-dollar weather disasters per year** in the US compared to an average of **13.1 in the previous decade** (NOAA).

Project Brief

In the aftermath of natural disasters, fragmented and otherwise unusable building materials often become waste. However, by combining these materials with Geopolymers, we can create innovative composite materials that are both resilient and sustainable. These composites have applications in creating fixtures for public gathering spaces, demonstrating a community's adaptability and resilience.

This approach not only fosters a sense of renewal and collective identity, but also supports critical environmental goals. By diverting debris from landfills and reducing the need for virgin building materials, this method promotes responsible waste management and minimizes the environmental impact of reconstruction.

United Nations Sustainable Development Goals

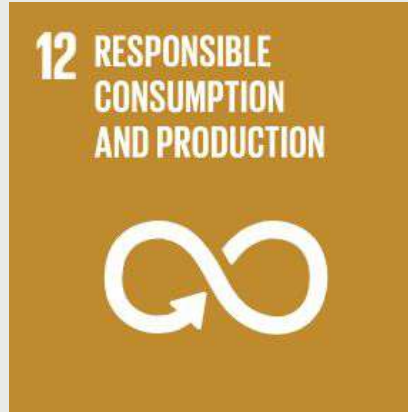

United Nations Sustainable Development Goals



United Nations Sustainable Development Goals



Geo + polymer

Geo : earth (mineral-based)

Polymer : chain of molecules

*Can be made with any locally sourced materials from the earth

United Nations Sustainable Development Goals



Traditional Portland cement accounts for **~8%** of global CO₂ emissions. By comparison, Geopolymer cement processes use **8x less CO₂** and **2-3x less energy** than Portland cement. Therefore, by using Geopolymers in combination with waste materials as aggregate, we can **reduce CO₂ emissions by ~80%**.

(Geopolymer International)

United Nations Sustainable Development Goals



Geopolymers have proven to be extremely resilient. They have an estimated lifespan of up to 10,000 years, are water and fireproof + acid resistant, have high strength and performance, and can also be combined with other materials to create composites.

(Geopolymer International)



Part 1: Contextualization



May 16, 2025
St. Louis, MO



————— The first deadly tornado since 1959 hits just 5 minutes after sirens go off.

May 16, 2025
St. Louis, MO

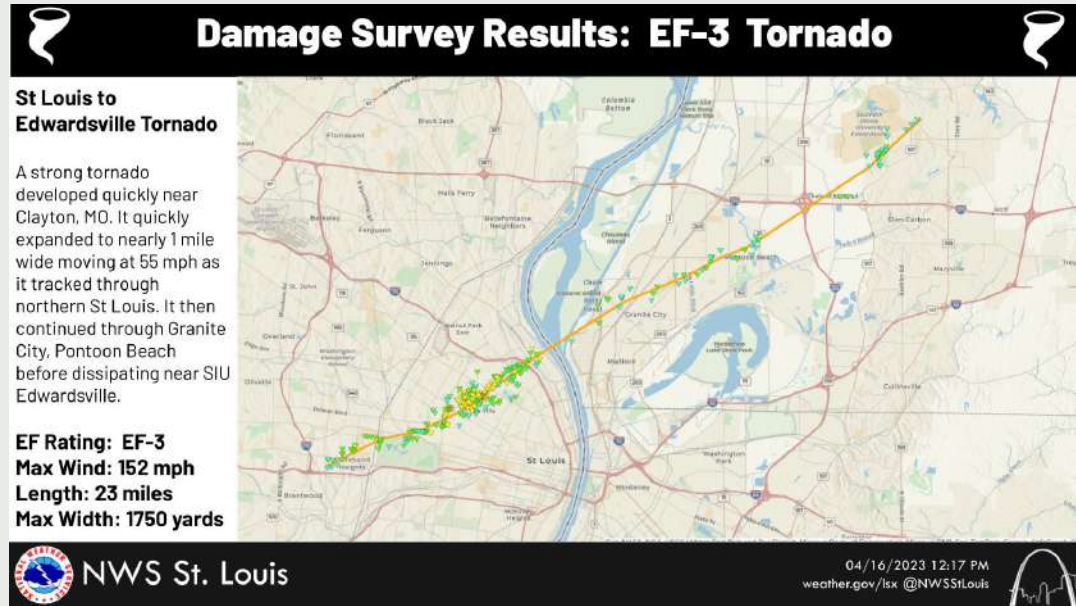

The tornado leaves a path of destruction 23 miles long, killing 4 people and damaging or destroying over 10,000 properties.

May 16, 2025
St. Louis, MO



The most severe damage is seen on the north side of the city which has been historically underserved. Estimated cost of damage is \$1.6 billion.



The ongoing recovery efforts have been unequal and inadequate.

As of late September debris in many North St. Louis neighborhoods **remained untouched**.
6 months later, debris remains.



With the slow response for cleanup, uninhabitable properties have been abandoned, leading to increased brick theft—an ongoing problem in St. Louis.

Historical significance of STL brick

The Great Fire of 1849 led to a brick mandate

1868 introduction of the hydraulic press allows new innovations for brick mfg.; use skyrockets

Post WWII brick mfg. declines

- Thousands of brick buildings demolished / abandoned contributing to **brick theft**
- Recent tornado has worsened theft

Brick theft: illegal harvesting and re-selling of bricks



The Big Question:

How can we aid in disaster recovery efforts, prevent brick theft, and bring communities together by designing for decarbonization?

Part 2: Solving (part of) the Problem



Step 1: Debris Removal

Estimated debris from May 16th tornado:

1 million tons

Combined debris from public and private properties
(Army Corps of Engineers)



How is debris handled?

Individuals expected to sort through debris and place it in public right-of-way areas for pickup.

- 4 categories:
 - Vegetation / green waste
 - Household Hazardous Waste
 - White Goods
 - Mixed Construction and Demolition



Where does the debris go?

Where does the debris go?

Short answer:

A green tractor is shown in the middle ground, working on a large pile of waste. The foreground and background are filled with various types of trash, including plastic, paper, and other debris. The overall scene is a typical landfill operation.

Landfills

How is debris handled?

Upon pickup

- Vegetative debris goes to St. Louis Composting Inc.
- **C&D materials are sent to a Waste Management Landfill**
(STL NPR)



Step 2: Intervention - Storage of Debris

Every year, nearly

145 million tons

of construction and demolition materials end up in a landfill. C&D waste accounts for $\frac{1}{3}$ of the total waste produced annually.

(EPA)



New Deconstruction Initiatives

Some cities have implemented **deconstruction ordinances** to keep C&D materials out of landfills.

- Portland, OR
- Pittsburgh, PA
- San Antonio, TX
- Milwaukee, WI
- Baltimore, MD
- Boulder, CO



Where does the material go?

Non-profit or commercial reuse centers

- The ReBuilding Center (Portland, OR)
- Urban Ore (Berkeley, CA)
- Material Innovation Center (San Antonio, TX)



How could St. Louis develop a system?

1. Create a centralized hub for receiving/sorting debris + manufacture/storage of new material
2. Invest in smaller, deployable nodes
 - Partner with existing salvage yards or organizations like **ReFab**



Partnership with Refab

“Refab reclaims and resells quality building materials, fixtures, and hardware.”

37,000 sq ft reuse center + Refab Lab

Looking to the future:

- Invest in additional space for debris storage and processing
- On-site fabrication lab for casting Geopolymers

(Refab)



Step 3: Incorporating Geopolymers

Geopolymer Composites

Geopolymer International has been experimenting with creating composite geopolymer materials. These have proven to be strong and durable, many with great insulative properties.

Wood Fiber Geopolymer

Geopolymer binder petrifies the cellulose in the wood, making it fire-resistant and insulative.



Recycled Plastic Geopolymer

Geopolymer combined with recycled plastic results in a lightweight and fire-resistant material that is great for insulating.



Granite / Basalt Geopolymer

Combining crushed granite or basalt with geopolymers results in an Ultra-High Performance geopolymer.



My Intervention



Waste → Aggregate



Recycled Concrete



Recycled Asphalt

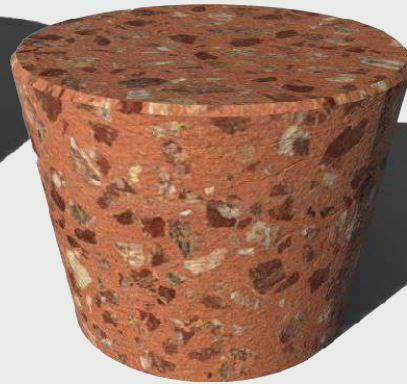

Recycled Brick



Recycled Brick + misc.

Brick Geopolymer

Giving a second life to STL brick by incorporating fragments into Geopolymers provides a promising avenue for preservation of STL history.

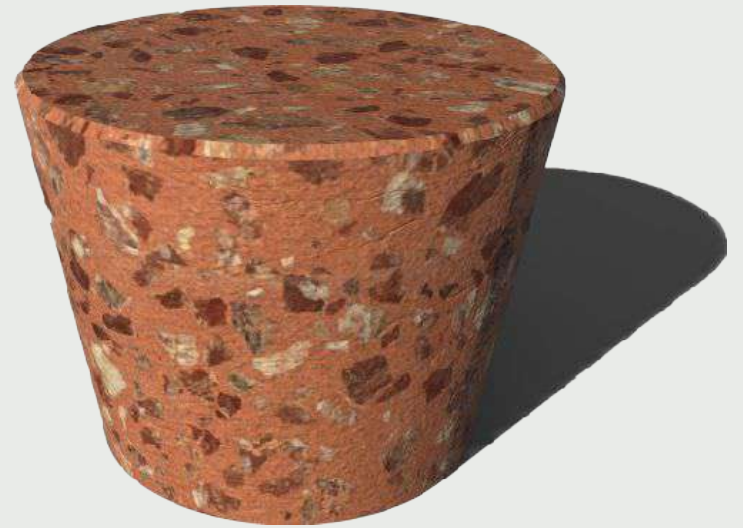



Step 4: Design for Community

Requirements

- Engages the local community
- Significant to St. Louis
- Repeatable in other cities

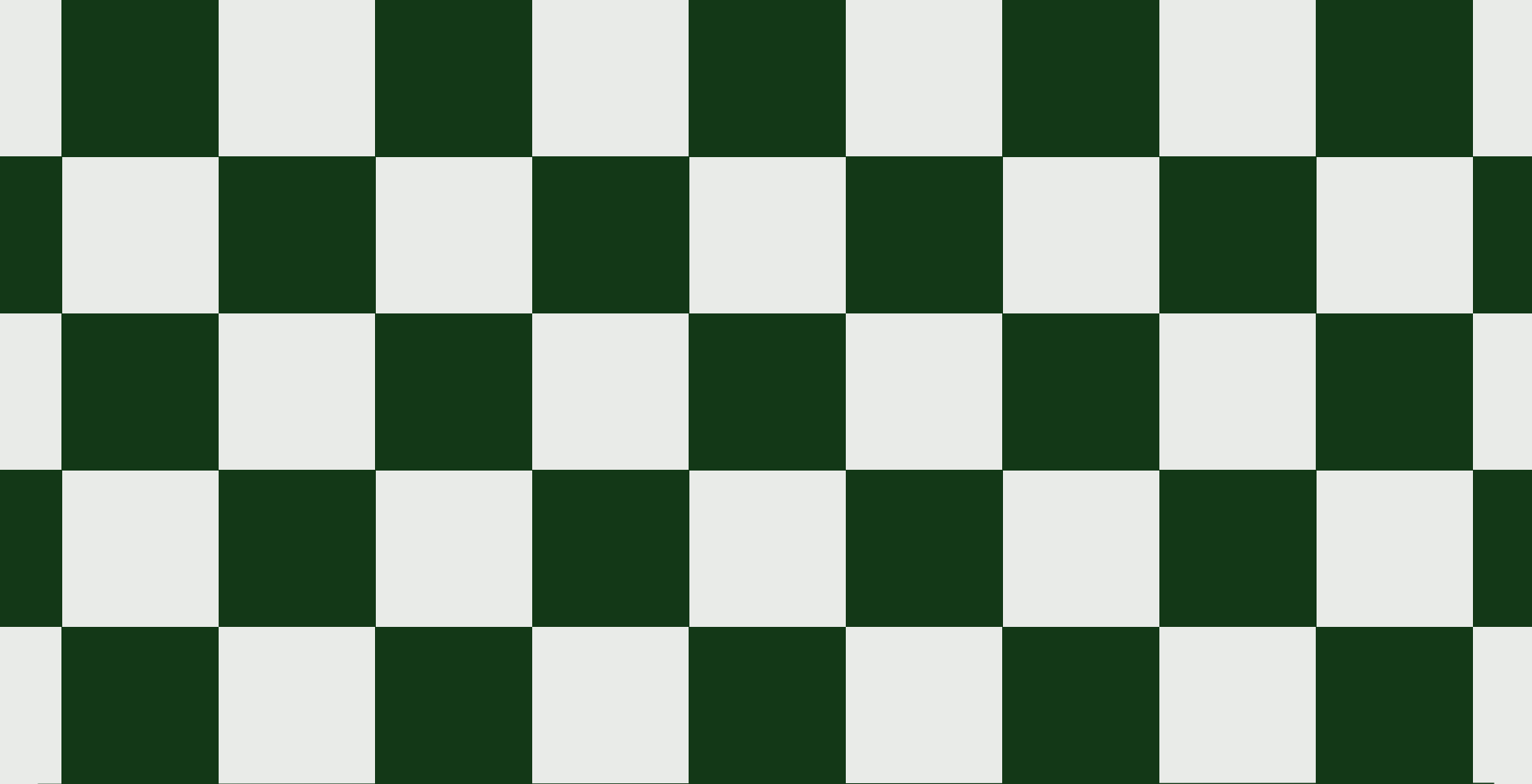

Anna Malinak

Parsons School of Design

MFA Industrial Design

Studio 3: Global Production

The image features a green and white checkerboard pattern. The word "CHESS" is written in a large, dark green, serif font, centered horizontally and vertically. The letters are slightly shadowed, giving them a three-dimensional appearance as if they are floating above the board.

CHESS



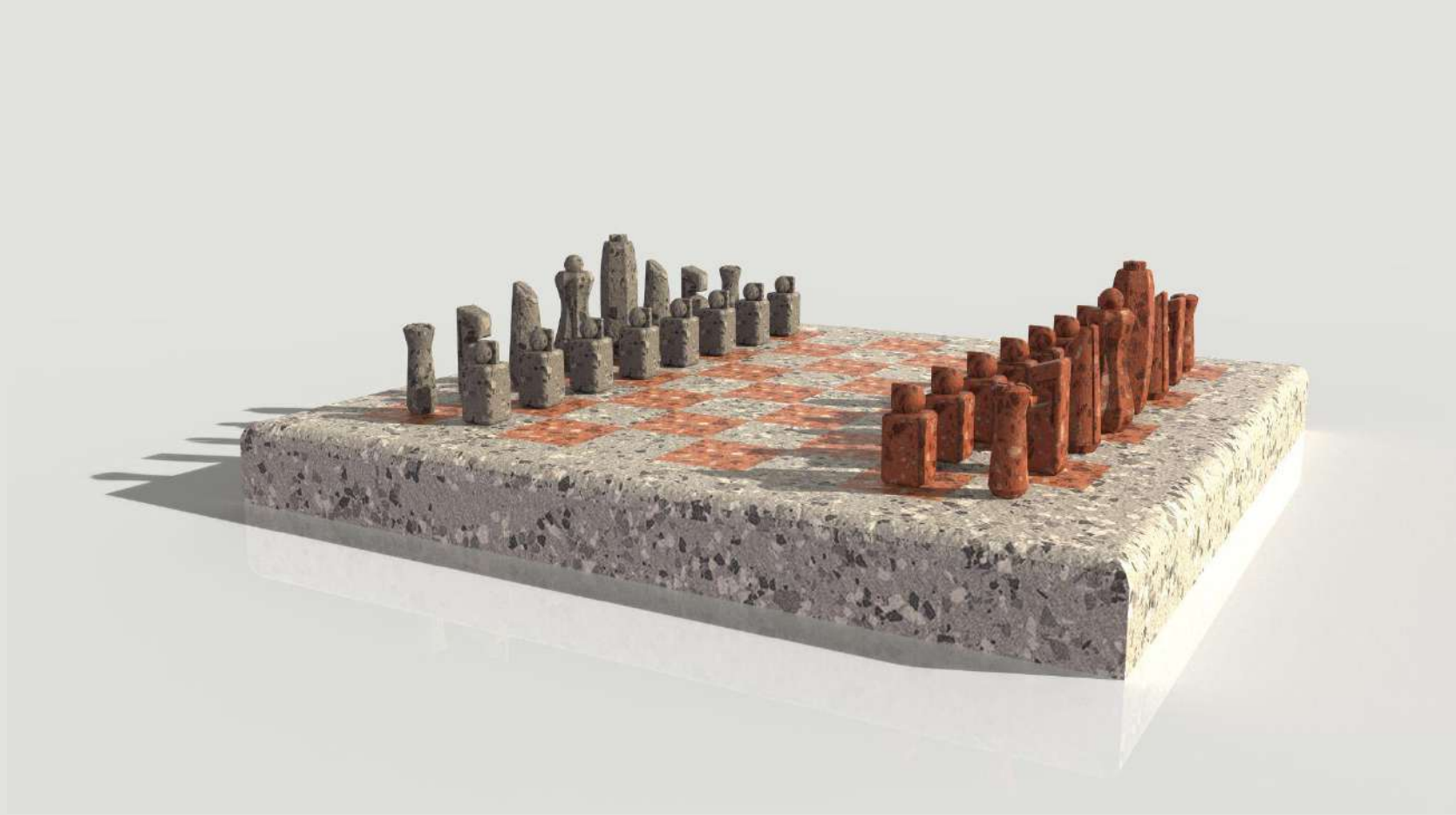

Design Intent

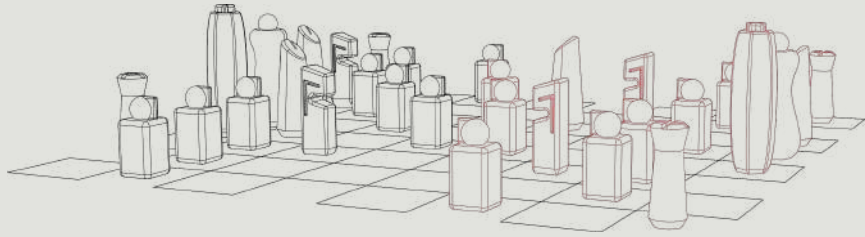

- Forms determined by pieces' movement patterns
- Still reminiscent of traditional pieces

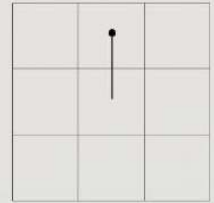
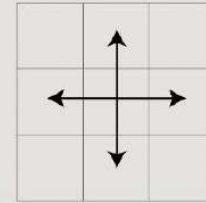
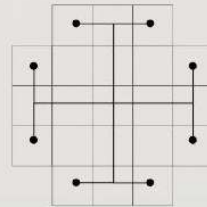
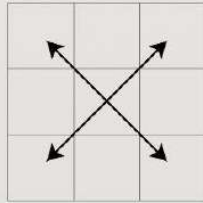
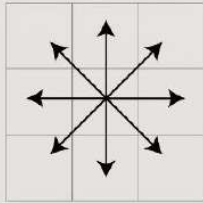
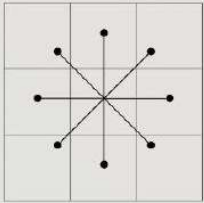

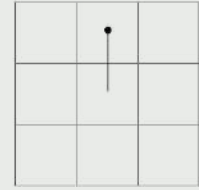
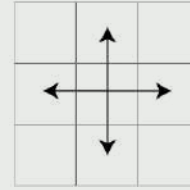
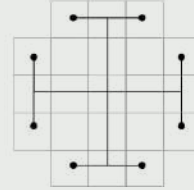
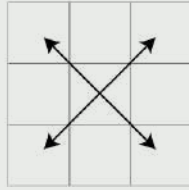
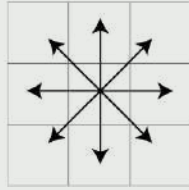
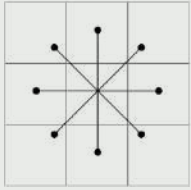

King

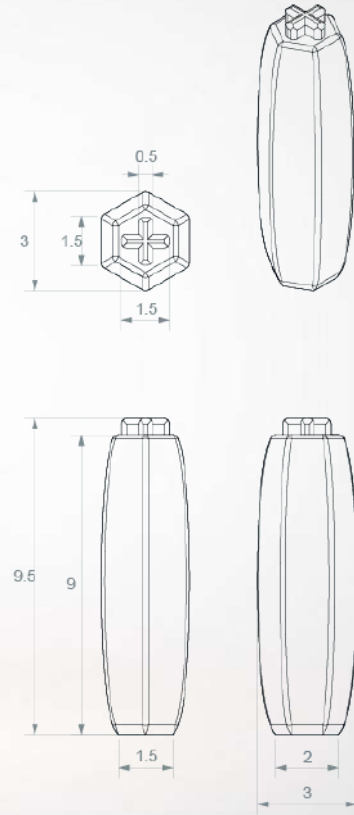

Queen

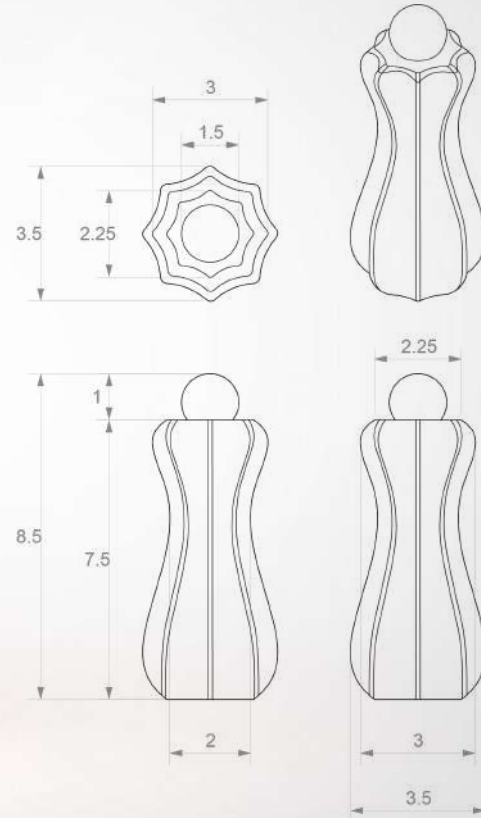

Bishop

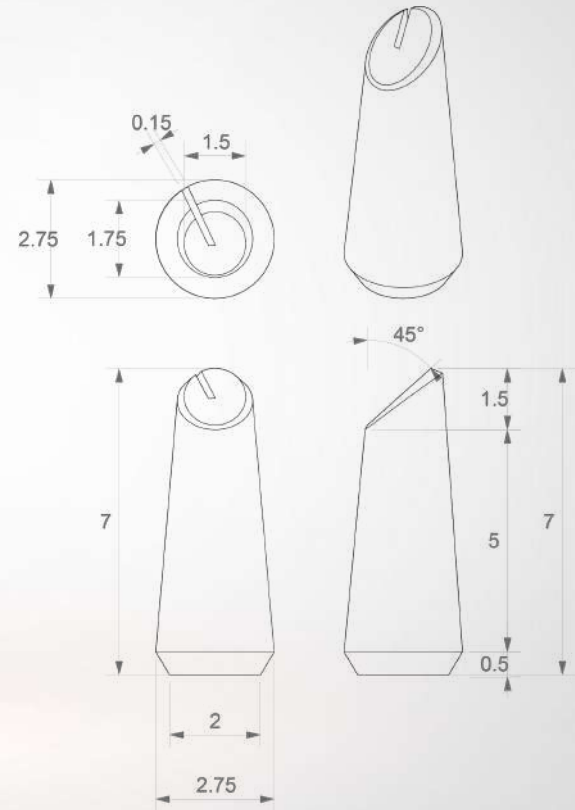

Knight

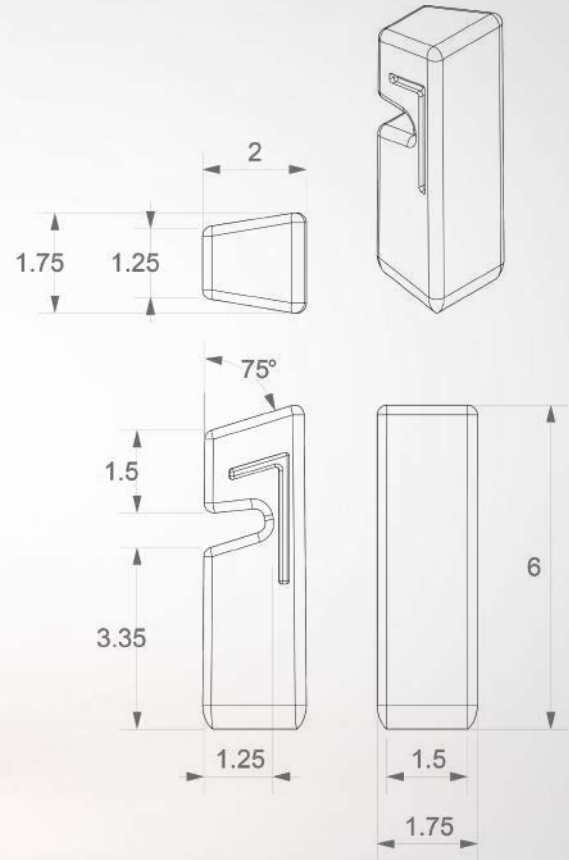
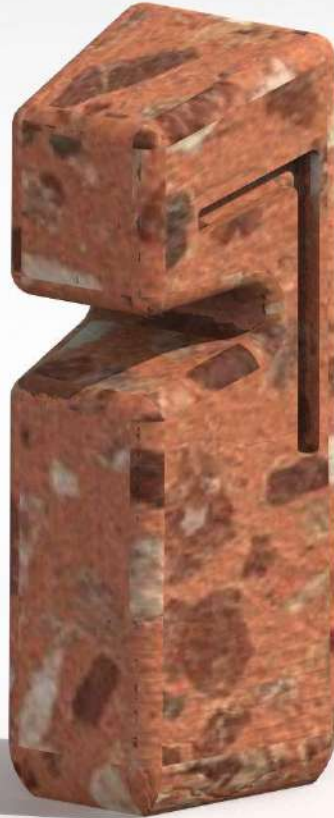

Rook

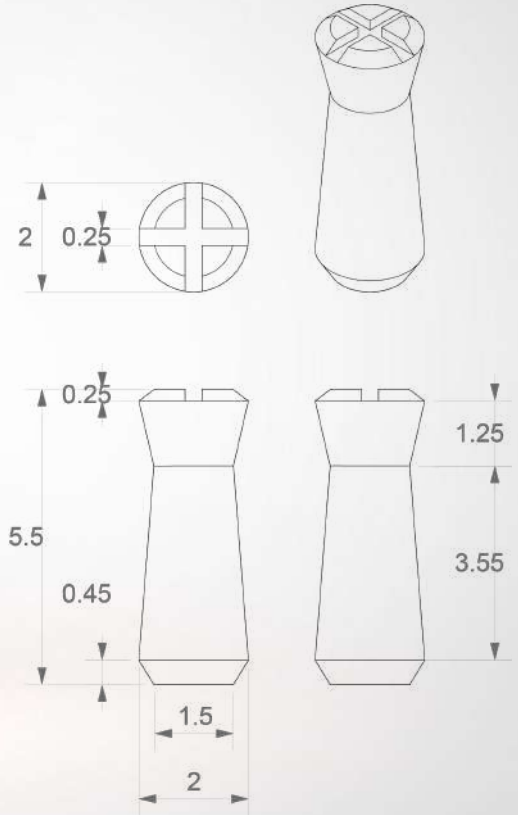

Pawn

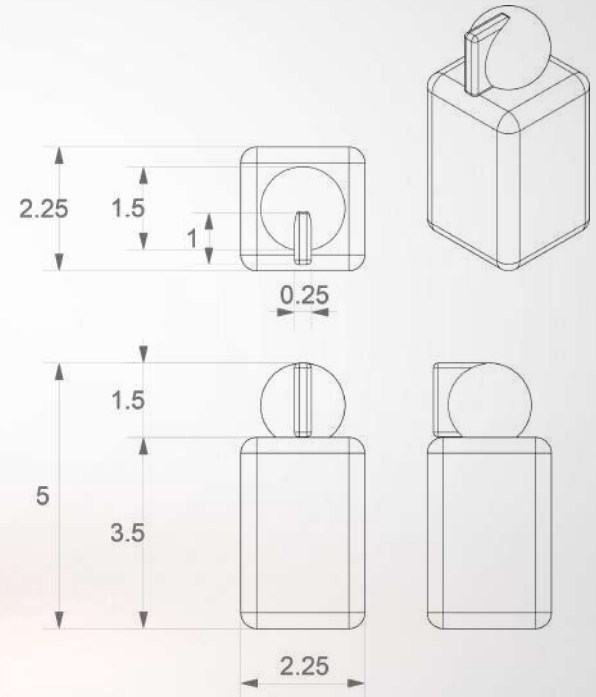

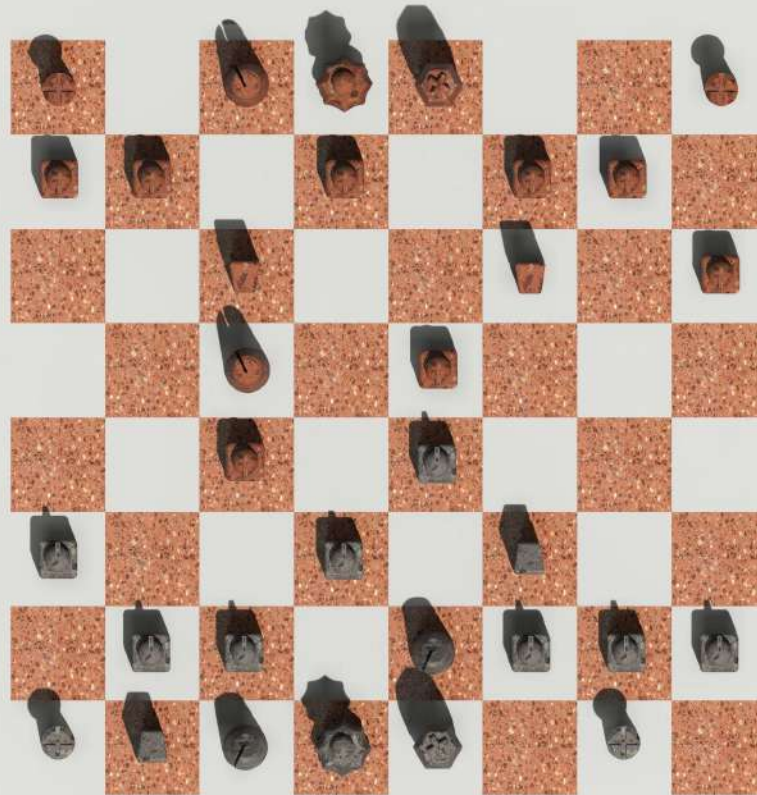



Step 5: Deployment of Artifacts



Anna Malinak

Parsons School of Design



MFA Industrial Design

Studio 3: Global Production

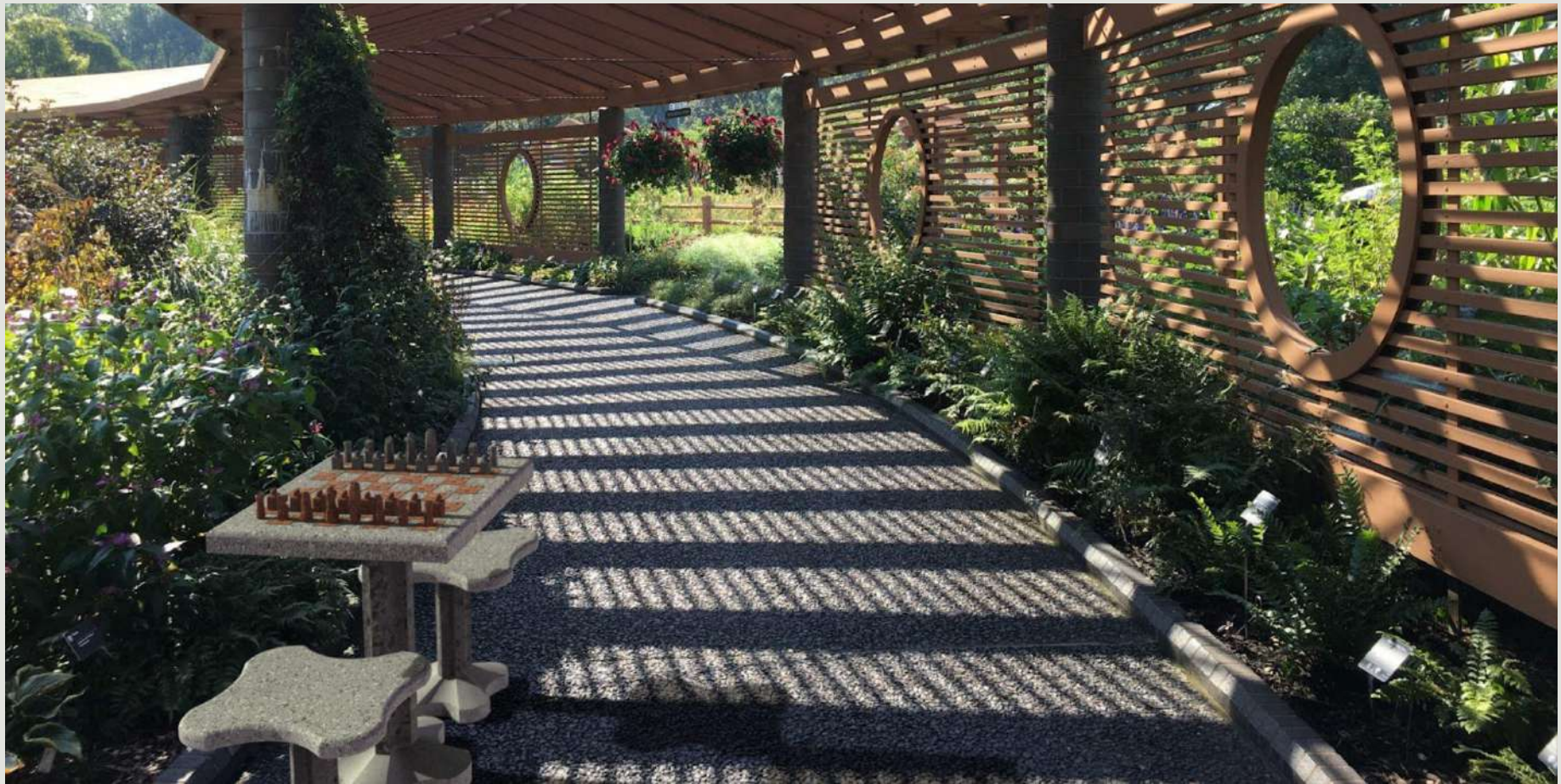





Anna Malinak

Parsons School of Design

MFA Industrial Design

Studio 3: Global Production





A green-tinted photograph of a park. In the center, a large, dark green archway frames the sky. Below the arch, a paved path leads through a grassy area with several people walking. In the background, there are trees and a building. The sky is blue with white clouds.

Thank you!